

THE INNOVATION IN POWDER COATING

ColorFlex

High Speed Color Changing System

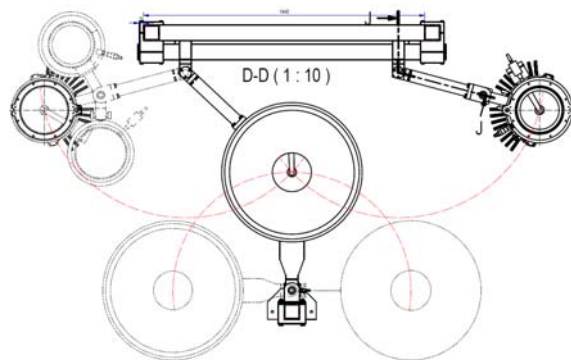
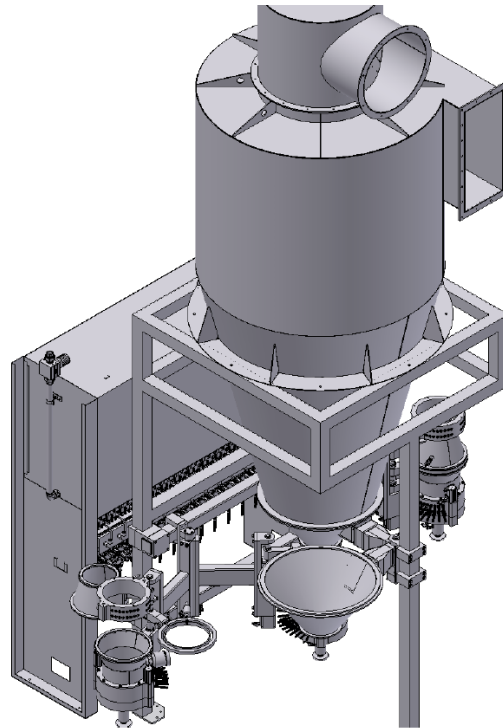

THE INNOVATION IN POWDER COATING

Economical small batch production on automatic powder booths.



Ramseier is well known for Fast Colour Change Systems and the Dense Flow Technology DDF. (Patent)
The next generation of quick colour change is ready now! ColorFlex, the High Speed Color Changing System Changes colours in 10 Seconds.....**it's magic!**
The latest development by Ramseier is the next quantum jump in the powder coating industry!
(Patent pend.)

What is well known in liquid applications is now possible also in the Powder Coating Industry.

The system is based on 2 Powder Management Centers PMC Tandem which work independent to each other, a system A and a system B

The heart of the system:

A colour change system per powder gun where the operator decides which colour from the system A or B he is using.
This colour change is during 10 seconds. (spray to waste)



The ColorFlex system contains following components:

1. **Colour Changer** – This system is mounted on each powder gun and is changing from powder hose A to B. In the cleaning mode each A-B hoses has a return hose back to the PMC A-B to recover all powder in the hose. In order to realise such a concept, hose lengths up to 40m are possible which is not at all a limitation for the Dense Flow Technology DDF which is one of the key elements of the total system.
2. **PMC Tandem** – This double system works independent from each other. One system is in production mode while the other is in cleaning and fill up mode.



THE INNOVATION IN POWDER COATING

The Process Flow:



System A:

This system is in application mode. The return hose to the PMC is closed. At the end of the coating process the hose gets purged and cleaned.

System B:

The return hose to the PMC opens and the hose to the application gets purged and cleaned. The PMC will be cleaned and the DDF pump recovers all powder in the hose back to the PMC for no loss of powder.



To change from system A to B takes 10 seconds!

2 Options of colour changes are possible:

High Speed on spray to waste
Fast colour change with powder recovery

Option 1: Spray to powder waste

Colour change in 10 seconds for small production batches
During the production with the PMC A the PMC B will be cleaned.

Option 2: Spray on powder recovery

Only the cleaning of the booth and cyclone are down time of the coating system.
The rest of the powder handling system PMC will be cleaned during the production time. This will take dependant on the quality of the colour change approx. 3-5 min (colour in colour)

The ColorFlex concept is available also as an upgrade system. The existing application system can be used

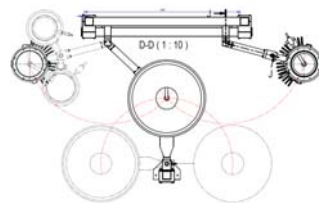

THE INNOVATION IN POWDER COATING

ColorFlex

High Speed Color Changing System

A Milestone in Powder Coating

or do you have time to waste?

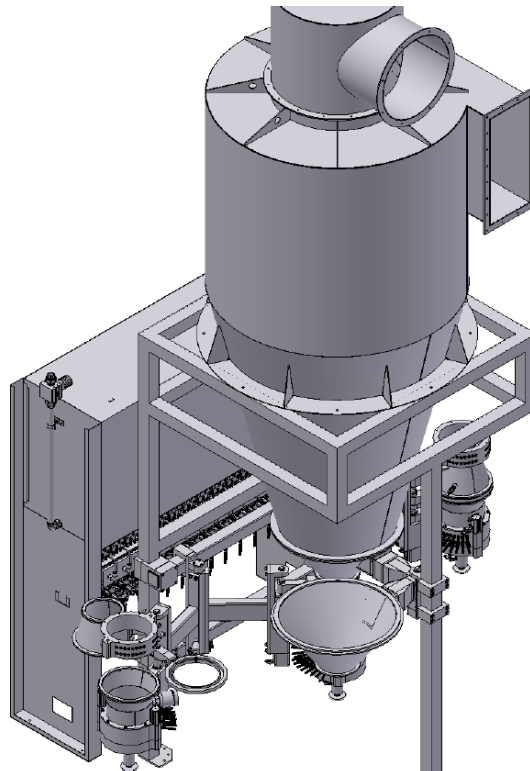

RAMSEIER KOATINGS TECHNOLOGIES AG
Nordstrasse 11e, CH-4542 Luterbach
Tel.: +41 (0)325 – 600600
Fax: +41 (0)325 – 600660
Email: info@ramseierkoatings.com
Web: www.ramseierkoatings.com

